



Manejadoras  
de enfriamiento  
EVAPORATIVO

**DAL**



**Soler&Palau**  
Ventilation Group

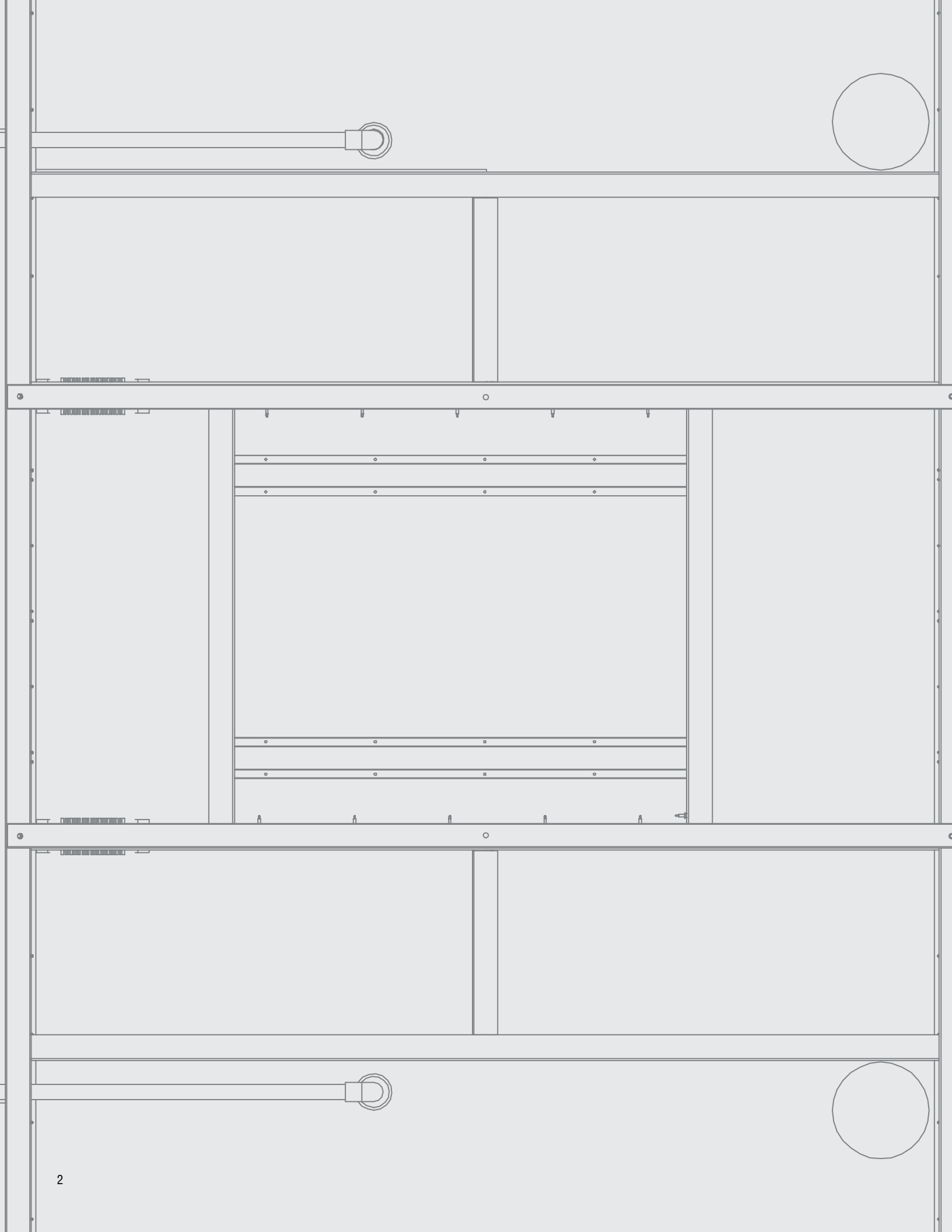



# Información general



Los equipos de **enfriamiento evaporativo de Soler & Palau, denominados DAL**, ofrecen una alternativa confiable para sistemas en los que es necesaria la disminución de temperatura por medio de un método sencillo y económico. Estos equipos, incorporan los mejores materiales en su fabricación con el fin de brindar al mercado un equipo de excelentes características y prestaciones caudal-presión.

Su diseño fue enfocado en cubrir las necesidades que la especificación de estos equipos requiere, buscando la mejora en eficiencia y el logro de un conjunto ventilador, caja y paneles de excelente calidad y con detalles insuperables por ningún otro equipo en el mercado.

## Nomenclatura

# DAL - H - 72 -12

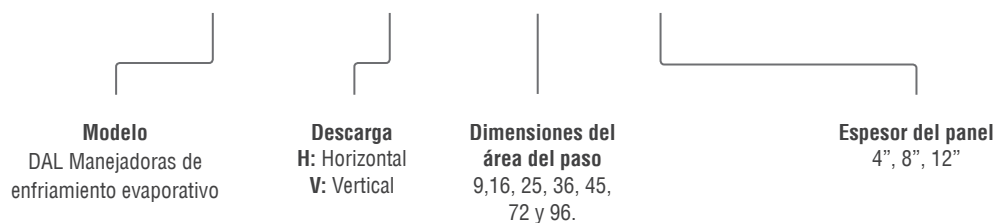

# Características constructivas

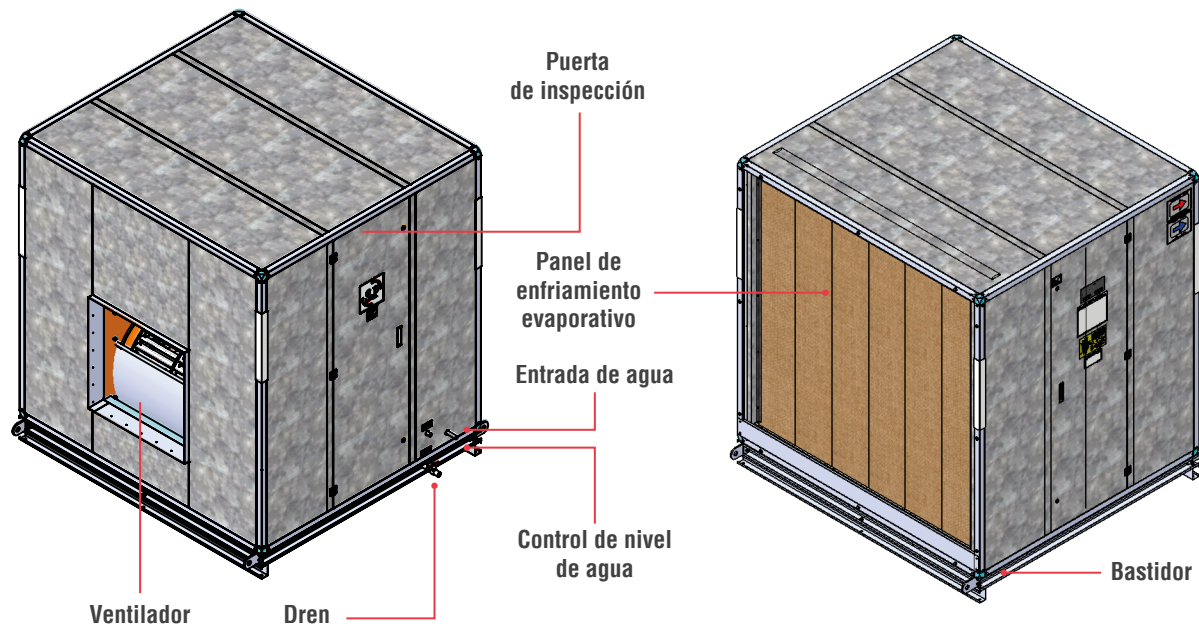

**Conjunto bastidor externo** en lámina galvanizada.

**Paneles, perfiles y pisos.** Fabricados en lámina galvanizada y con acabado en pintura de polvo poliéster.

**Ventilador centrífugo de doble aspiración,** con rodete de álabes curvos adelantados y balanceado dinámicamente a grado G 6.3 siguiendo lo establecido por la normativa ISO 1940 o AMCA 204. Además de que han sido aprobados para tener el sello de prestaciones certificadas por AMCA de acuerdo con procedimientos desarrollados con la publicación AMCA 211.

**Tinas fabricadas en resina poliéster ortoftálica** reforzada con fibra de vidrio. Recubierto con acabado GEL-coat, material utilizado para dar características de calidad a la superficie de un material compuesto con fibra reforzada. Dando como resultado un acabado pigmentado y brillante. Sobre pedido en material de acero inoxidable.

**Puertas de inspección** con cierres hexagonales y bisagras (para tamaños aplicables).

**Sistema de circulación de agua** en tubería de PVC con entrada de agua, válvula de paso, dren para mantenimiento y tubo para el control del nivel cuando la bomba es apagada.

**Panel de enfriamiento evaporativo** de papel corrugado 100% celulosa de madera, así como resinas de la más alta calidad. Contiene aditivos y bactericidas especiales para evitar la formación de microorganismos y espuma. La velocidad máxima sin arrastre de agua es de 700ppm.

**Interruptor de nivel** se activa por presión a un diafragma, que a su vez activa un conmutador suministrando energía eléctrica a la bomba. La presión sobre el diafragma es causada por la elevación del nivel del agua alrededor de la caja del interruptor.

\*Los dibujos mostrados son únicamente ilustrativos.



Gráficas de **comportamiento de humidificación** y **caída de presión** del panel de enfriamiento Evaporativo.

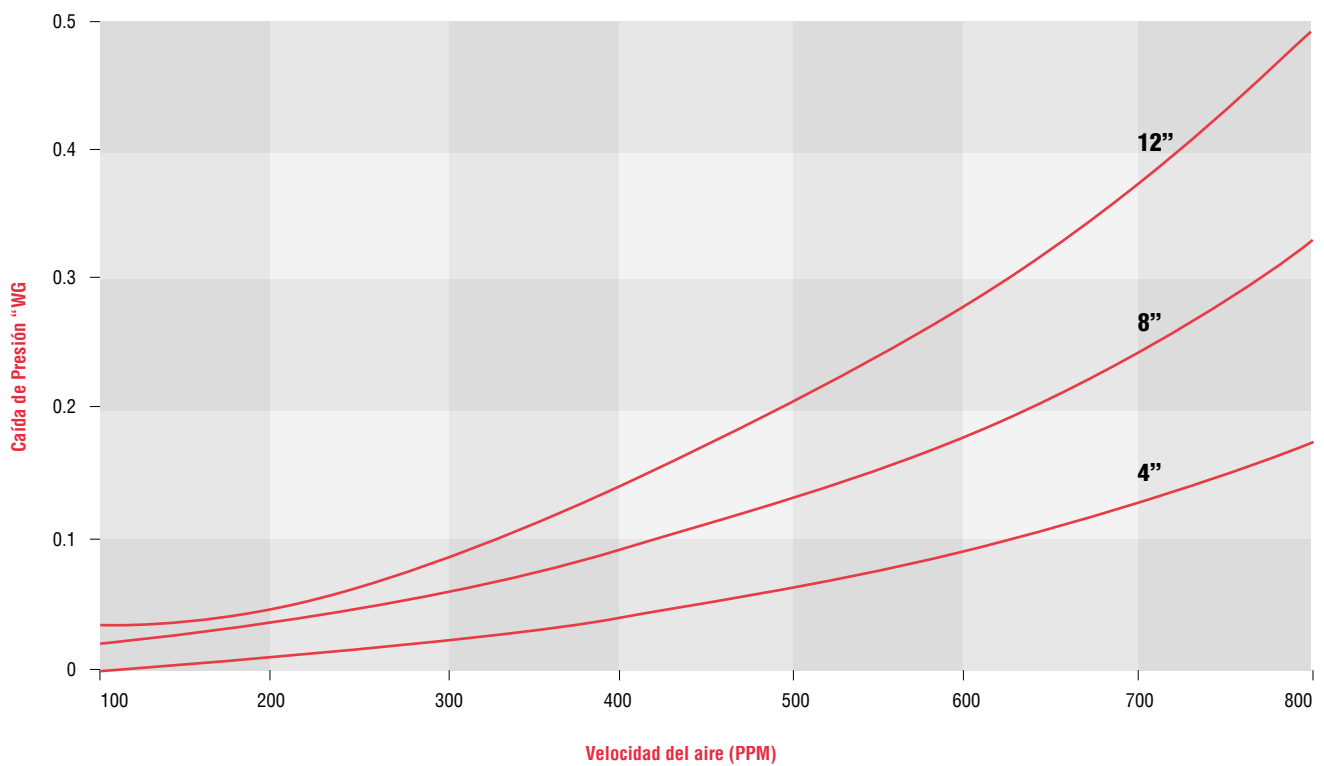
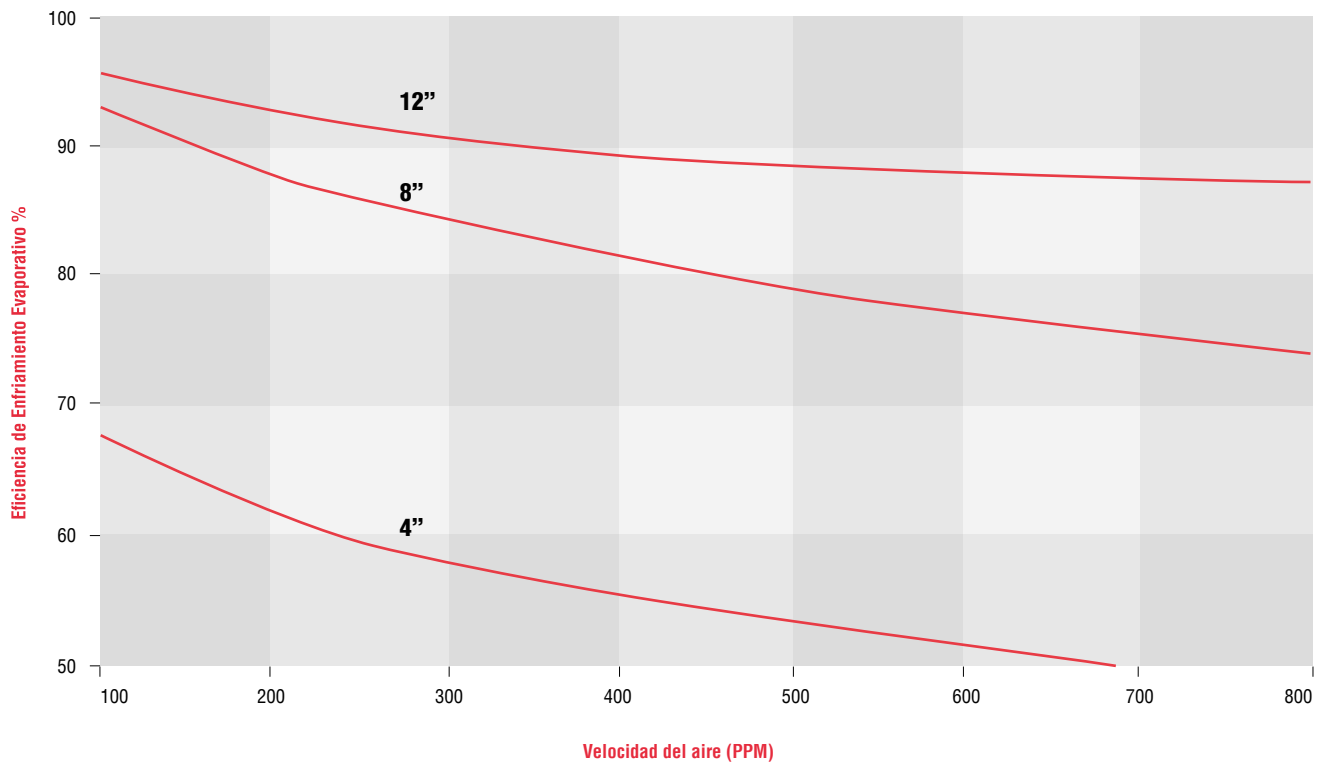



# Características técnicas

Modelo	Potencia HP	Caudal a descarga libre		Dimensiones panel			Cantidad de paredes panel	Área total del panel ft²	Cantidad de bombas	Modelo de bombas	Peso equipo sin motor y agua Lb(Kg)
		CFM	m³/hr	A in (mm)	B in (mm)	C in (mm)					
DAL 9	1/3	3,384	5,750	8 [203.2]	12 [304.8]	36 [914.4]	1	9	1	CP2- Little Giant	287(130)
	1/2	4,120	7,000								
	3/4	4,856	8,250								
	1	5,592	9,500								
	1 1/2	6,828	11,600								
DAL 16	1/2	5,886	10,000	12 [304.8]	12 [304.8]	48 [1219.2]	1	15	1	CP2- Little Giant	661(300)
	3/4	7,004	11,900								
	1	8,044	13,666								
	1 1/2	9,358	15,900								
	2	10,300	17,500								
	3	11,477	19,500								
DAL 25	1	9,712	16,500	12 (304.8)	12 [304.8]	60 (1524)	1	25	1	CP2-Little Giant	935 (424)
	1 1/2	10,948	18,600								
	2	12,301	20,900								
	3	14,067	23,900								
	5	16,098	27,350								
DAL 36	1 1/2	11,389	19,350	12 (304.8)	12 [304.8]	72 (1828.8)	1	36	1	5-MSP Little Giant	1449 (657.2))
	2	12,875	21,875								
	3	14,715	25,000								
	5	18,025	30,625								
	7 1/2	19,865	33,750								
	10	24,279	41,250								
DAL 45	1	8,181	13,900	12 (304.8)	12 [304.8]	72 (1828.8)	1	45	1	5-MSP Little Giant	2120(961.4))
	1.5	11,477	19,500								
	2	14,126	24,000								
	3	18,835	32,000								
	5	22,248	37,800								
	7.5	26,251	44,600								
DAL 72	5	22,072	37,500	12 [304.8]	12 [304.8]	72 [1828.8]	2	72	2	5-MSP Little Giant	2,116 (960)
	7 1/2	25,750	43,750								
	10	28,693	48,750								
	15	34,550	58,700								
	20	38,258	65,000								
DAL 96	10	36,816	62,550	12 [304.8]	12 [304.8]	72 [1828.8]	2	96	2	5-MSP Little Giant	2,910 (1320)
	15	43,408	73,750								
	20	47,822	81,250								
	25	51,501	87,500								
	30	55,915	95,000								

\*Suministro de diferente voltaje en bombas bajo cotización y verificación del tiempo de entrega.

# Despiece del producto

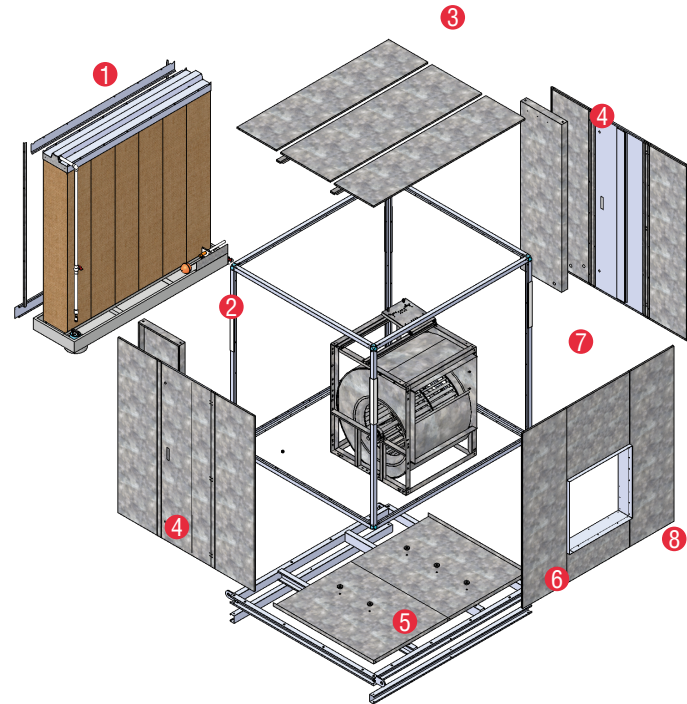

- 1 Conjunto sistema hidráulico.
- 2 Perfiles omegas.
- 3 Panelización techo.
- 4 Estructura panelizada.
- 5 Conjunto bastidor piso.
- 6 Estructura panelizada.
- 7 Ventilador de álabes adelantados.
- 8 Brida descarga.

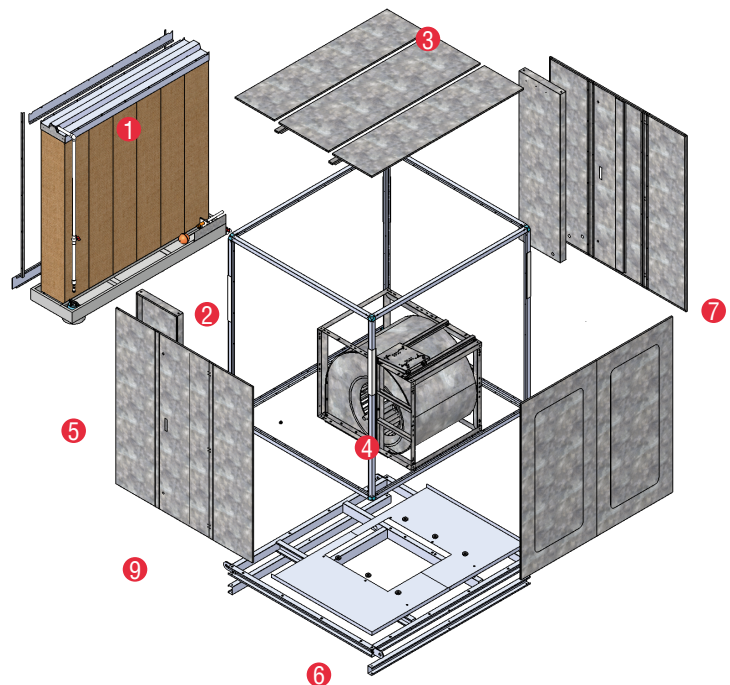

- 1 Conjunto sistema hidráulico (Panel-charola).
- 2 Perfiles omegas.
- 3 Panelización techo.
- 4 Ventilador álabes adelantados.
- 5 Estructura panelizada.
- 6 Conjunto bastidor piso.
- 7 Estructura panelizada.
- 8 Conjunto sistema hidráulico (Panel-charola).
- 9 Brida descarga.

\*Los dibujos mostrados son únicamente ilustrativos.

# Ejemplo de selección

## Especificaciones de selección:

Se tiene un gimnasio donde se requiere colocar una unidad lavadora de aire; las dimensiones del gimnasio son: **15 m x 30 m y 3 m de alto** y se tiene una pérdida de carga por ductería de **0.315 inwg**.

Para poder determinar el caudal necesario del equipo, se tiene que calcular el volumen del gimnasio.

$$\text{Volumen} = \text{Largo} \times \text{Ancho} \times \text{Alto}$$

$$\text{Volumen} = (15 \text{ m} \times 30 \text{ m}) (3 \text{ m}) = \mathbf{1,350 \text{ m}^3}$$

Una vez calculado el volumen, se escogerá el número de renovaciones por hora que mejor se adapte a las necesidades del local (en este caso el gimnasio), ayudándonos de la tabla siguiente.

Sector servicios y locales	NR / h
Aula	2 - 4
Bancos	3 - 4
Café	10 - 12
Biblioteca	3 - 5
Cines - teatros	10 - 15
Concina industrial	15 - 30
Comedores - cantina	5 - 10
Estudios de grabación	10 - 12
Garaje	6 - 8
<b>Gimnasio</b>	<b>6 - 12</b>
Hall de entrada	3 - 5
Hospitales	4 - 6
Lavanderías	15 - 30
Oficinas	4 - 8
Panadería	20 - 30
Restaurante	5 - 10
Sala de baile	6 - 8
Sala de conferencias	8 - 12
Sala de reuniones	4 - 8

Debido a las actividades y fluencia de personas en dicho gimnasio se utilizaran 12 renovaciones por hora.

$$Q = V \times NR / H$$

$$Q = 1,350 \text{ m}^3 \times 12 / \text{hr} = \mathbf{16,200 \text{ m}^3 / \text{hr}}$$

Una vez calculado el caudal necesario y la presión establecida, encontramos el **modelo DAL 25**, que es el que se adapta a las necesidades del gimnasio.



HP	PRESIÓN ESTÁTICA inwg / mmca											
	0.250" / 6.35 mm		0.312" / 7.93 mm		0.375" / 9.53 mm		0.438" / 11.11 mm		0.500" / 12.7 mm		0.625" / 15.87 mm	
	RPM dB(A)	CFM m³/hr	RPM dB(A)	CFM m³/hr	RPM dB(A)	CFM m³/hr	RPM dB(A)	CFM m³/hr	RPM dB(A)	CFM m³/hr	RPM dB(A)	CFM m³/hr
1	298	8,550	300	8,015	308	7,392	317	6,769	342	6,338	363	5,429
	62.7	14,527	62.9	13,618	60.7	12,559	61.5	11,500	61.2	10,769	60.5	9,224
1 1/2	315	9,980	322	9,633	329	9,199	344	8,851	358	8,504	385	7,723
	65.2	16,956	65.6	16,366	64.0	15,629	65.2	15,039	64.7	14,449	64.7	13,122
2	350	11,362	359	10,878	365	10,636	370	10,066	375	9,719	396	9,025
	67.7	19,304	68.1	18,482	66.7	18,071	67.3	17,103	66.6	16,513	66.6	15,333
3	406	13,054	404	12,691	403	12,329	402	12,087	400	11,604	425	10,999
	70.9	22,179	71.0	21,563	69.3	20,947	70.1	20,536	69.0	19,714	69.5	18,688
5	475	15,273	478	14,926	480	14,752	485	14,578	491	14,405	496	14,058
	74.3	25,949	74.6	25,359	73.1	25,064	74.2	24,769	73.7	24,474	73.7	23,884

Entrando a la tabla de la DAL 25, con 0.312 inwg y 16,366 m³/hr, encontramos el resto de los datos.

**Potencia:** 1 1/2 HP

**Velocidad del ventilador:** 322 rpm

**Nivel sonoro:** 65.6 dB(A)

**Selección realizada a condiciones estándar:** 0 m.s.n.m. (0 ft.s.n.m.), 20 °C (70 °F), **Densidad del aire:** 1.2 kg / m³ (0.075 lb/ft³).



## Características principales DAL 9

	Especificación				
	No. Paredes	Área de paso	Panel de enfriamiento evaporativo		Espesor
Área filtrante	1	9 ft <sup>2</sup> [ 0.84 m <sup>2</sup> ]	Papel corrugado 100% celulosa de madera, así como resinas de la más alta calidad. Contiene aditivos y bactericidas especiales para evitar la formación de microorganismos y espuma.		8 in [203 mm]
Bomba	Modelo	Voltaje	Hz	Potencia HP	Nota
	CP2-115 Little Giant	115	60	1/50	Estándar
Componentes	Chumaceras	Número de tinas		Capacidad en Litros por tina	
	De piso	1		28.85	
Conjunto	Caudal Máx.	Presión Est. Máx.	Potencia Máx.	Velocidad de paso Máx.	RPM Máx.
	6,828 CFM [11,600 m <sup>3</sup> /hr]	1 inwg [ 25.4 mmca ]	1.12 Kw [ 1 1/2 HP ]	699 ft/min [ 3.55 m/seg ]	702
Accesorios	Louwer en succión	Damper en succión	Malla desplegada en succión	Portafiltros / Filtros metálico	Tina de acero inoxidable

HP	PRESIÓN ESTÁTICA inwg / mmca									
	0.250" / 6.35 mm		0.312" / 7.93 mm		0.375" / 9.53 mm		0.438" / 11.11 mm		0.500" / 12.7 mm	
	RPM dB(A)	CFM m <sup>3</sup> /hr	RPM dB(A)	CFM m <sup>3</sup> /hr	RPM dB(A)	CFM m <sup>3</sup> /hr	RPM dB(A)	CFM m <sup>3</sup> /hr	RPM dB(A)	CFM m <sup>3</sup> /hr
1/3	385	3,282.8	390	3,181.3	408	2,978.2	440	2,775.2	465	2,551.1
	61.3	5,577.5	59.2	5,405	57.4	5,060	55.7	4,715	54.2	4,334.4
1/2	398	3,902.3	402	3,722.8	431	3,583.3	445	3,386.4	478	3,215.1
	63.5	6,630	61.3	6,325	59.6	6,088	58	5,753.5	56.6	5,462.5
3/4	415	4,581.5	430	4,425.4	456	4,373.9	460	4,139.1	483	3,976.6
	65.6	7,784	63.5	7,518.7	61.8	7,431.3	60.3	7,032.3	58.9	6,756.3
1	495	5,310.8	490	5,102.2	498	5,050.8	497	4,894.4	501	4,790.2
	69.9	9,023	67.7	8,668.7	66.1	8,581.3	64.6	8,315.7	63.4	8,138.6
1 1/2	580	6,518.2	570	6,294.9	530	6,091.8	570	5,888.8	575	5,687.7
	74.2	11,074.5	72.1	10,695	70.3	10,350	68.8	10,005	67.5	9,663.5

HP	PRESIÓN ESTÁTICA inwg / mmca									
	0.625" / 15.88 mm		0.687" / 17.46 mm		0.75" / 19.05 mm		0.875" / 22.23 mm		1.00" / 25.4 mm	
	RPM dB(A)	CFM m <sup>3</sup> /hr	RPM dB(A)	CFM m <sup>3</sup> /hr	RPM dB(A)	CFM m <sup>3</sup> /hr	RPM dB(A)	CFM m <sup>3</sup> /hr	RPM dB(A)	CFM m <sup>3</sup> /hr
1/3	542	2,050.9	590	1,621.1	615	1,602.8				
	51.3	3,484.5	49.8	2,754.3	48.6	2,723.2				
1/2	520	2,988.4	555	2,775.2	593	2,685.8	650	2,316.7	702	1,977
	54.3	5,077.3	53.2	4,715	52.3	4,563.2	61.3	3,936	48.5	3,359
3/4	518	3,682.2	550	3,583.3	575	3,453.4	615	3,147.7	678	2,877
	56.6	6,256	55.7	6,088.1	54.8	5,867.3	64	5,348	51.4	4,888
1	538	4,477.5	560	4,373.9	570	4,269.7	608	3,976.6	660	3,742.2
	61.1	7,607.3	60.2	7,431.3	59.4	7,254.2	68.7	6,756.3	56.3	6,358
1 1/2	580	5,448.8	593	5,414.9	601	5,310.8	630	5,102.2	680	4,894.6
	65.4	9,257.5	64.6	9,200	63.7	9,023	73.2	8,668.7	60.9	8,316

No seleccionar (velocidad de paso fuera de la recomendada).

Condiciones Estándar : 0 m.s.n.m. y 20°C.



Dimensiones **DALH 9**

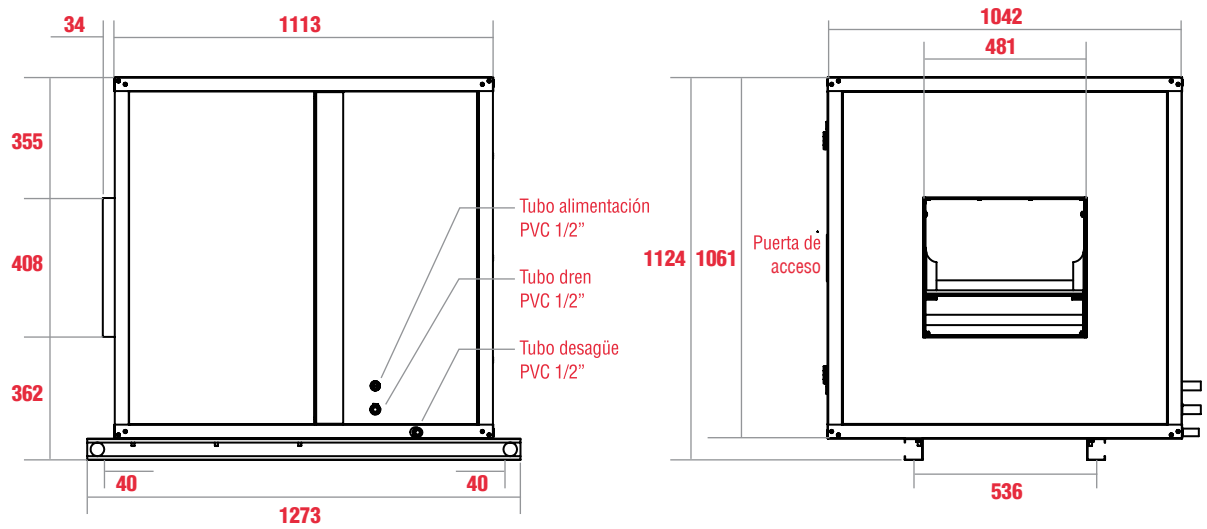

Dimensiones **DALV 9**

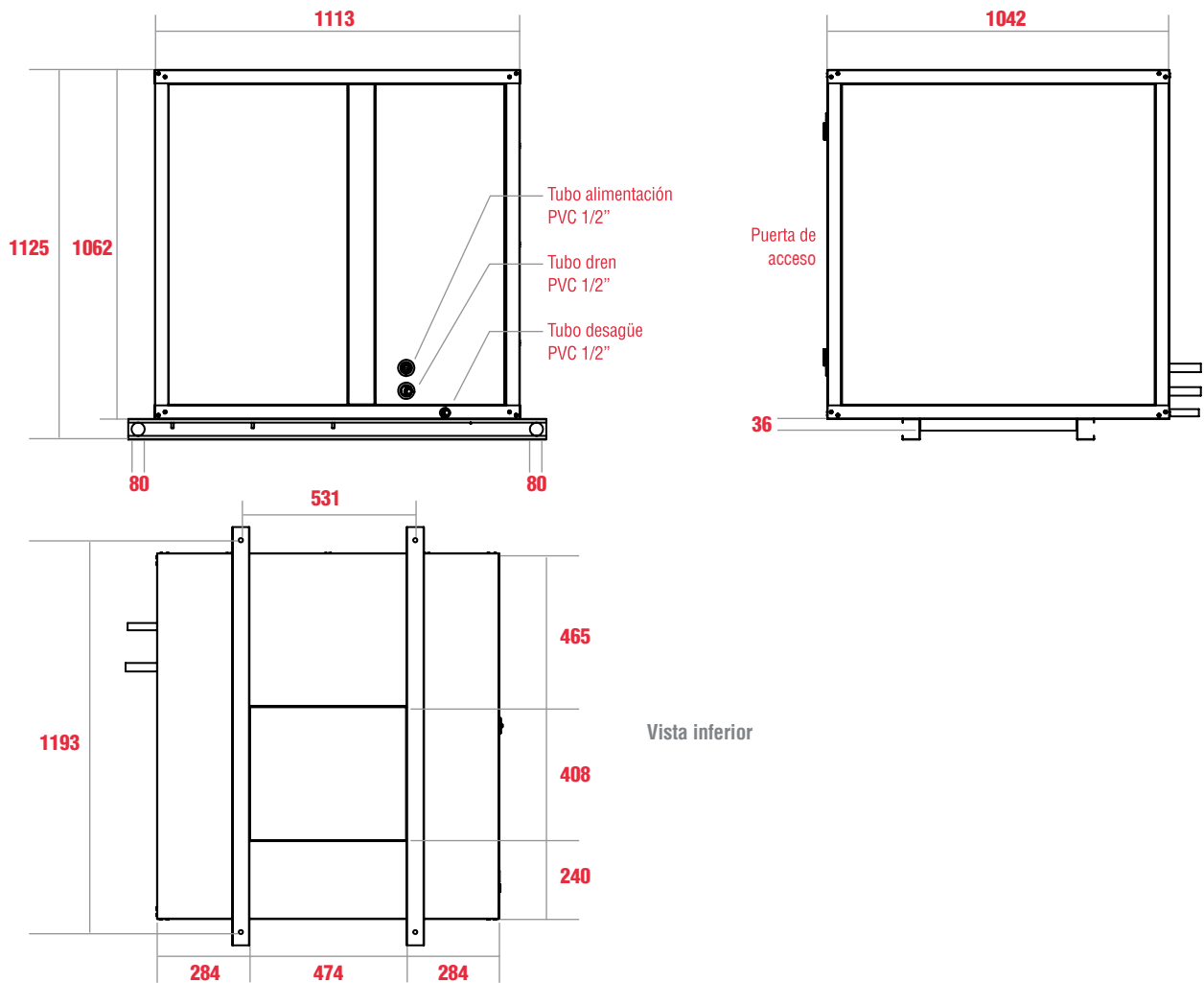



Características principales **DAL 16**

	Especificación				
	No. Paredes	Área de paso	Panel de enfriamiento evaporativo		Espesor
Área filtrante	1	16 ft <sup>2</sup> [ 1.486 m <sup>2</sup> ]	Papel corrugado 100% celulosa de madera, así como resinas de la más alta calidad. Contiene aditivos y bactericidas especiales para evitar la formación de microorganismos y espuma.		12 in [304.8 mm]
Bomba	Modelo	Voltaje	Hz	Potencia HP	Nota
	CP2-115 Little Giant	115	60	1/50	Estándar
Componentes	Chumaceras	Número de tinas		Capacidad en Litros por tina	
	De piso	1		48.60	
Conjunto	Caudal Máx.	Presión Est. Máx.	Potencia Máx.	Velocidad de paso Máx.	RPM Máx.
	11,477 CFM [19,500 m <sup>3</sup> /hr]	1 inwg [ 25.4 mmca ]	2.24 Kw [ 3 HP ]	682 ft/min [ 3.46 m/seg ]	548
Accesorios	Louver en succión	Damper en succión	Malla desplegada en succión	Portafiltros / Filtros metálico	Tina de acero inoxidable

HP	PRESIÓN ESTÁTICA inwg / mmca									
	0.250" / 6.35 mm		0.312" / 7.93 mm		0.375" / 9.53 mm		0.438" / 11.11 mm		0.500" / 12.7 mm	
	RPM dB(A)	CFM m <sup>3</sup> /hr	RPM dB(A)	CFM m <sup>3</sup> /hr	RPM dB(A)	CFM m <sup>3</sup> /hr	RPM dB(A)	CFM m <sup>3</sup> /hr	RPM dB(A)	CFM m <sup>3</sup> /hr
1/2	294	5,102	303	5,259	321	4,362	347	3,981	370	3,663
	61.4	8,669	63.0	8,934	61.3	7,411	63.6	6,764	63.5	6,224
3/4	318	6,295	329	6,032	350	5,686	358	5,363	383	5,102
	64.4	10,695	65.3	10,249	65.0	9,660	67.0	9,111	67.3	8,669
1	350	7,318	367	6,860	372	6,760	381	6,498	395	6,102
	67.0	12,433	67.9	11,655	67.4	11,485	69.6	11,040	69.4	10,367
1 1/2	388	8,690	398	8,323	400	8,049	411	7,683	412	7,318
	70.0	14,764	70.8	14,142	70.0	13,676	72.2	13,054	71.7	12,433
2	406	9,513	425	9,330	433	8,964	442	8,872	452	8,690
	71.4	16,162	72.7	15,852	72.0	15,229	74.5	15,074	74.6	14,764
3	475	10,905	481	10,780	487	10,529	492	10,403	496	10,152
	74.6	18,528	75.6	18,315	75.0	17,889	77.4	17,676	77.2	17,248

HP	PRESIÓN ESTÁTICA inwg / mmca									
	0.625" / 15.88 mm		0.687" / 17.46 mm		0.75" / 19.05 mm		0.875" / 22.23 mm		1.00" / 25.4 mm	
	RPM dB(A)	CFM m <sup>3</sup> /hr	RPM dB(A)	CFM m <sup>3</sup> /hr	RPM dB(A)	CFM m <sup>3</sup> /hr	RPM dB(A)	CFM m <sup>3</sup> /hr	RPM dB(A)	CFM m <sup>3</sup> /hr
1/2	413	3,015								
	63.7	5,123								
3/4	414	4,374	439	4,061	458	3,782				
	67.9	7,431	61.4	6,900	61.1	6,426				
1	428	5,415	441	5,154	461	4,842	491	4,374	523	3,893
	70.0	9,200	63.8	8,757	63.3	8,227	63.4	7,431	60.5	6,615
1 1/2	439	6,566	453	6,363	483	6,108	497	5,550	525	5,102
	72.3	11,155	66.3	10,810	66.5	10,378	65.9	9,430	63.3	8,669
2	472	8,283	477	8,015	488	7,682	501	7,125	533	6,735
	75.5	14,073	69.2	13,618	69.0	13,051	68.5	12,105	66.2	11,443
3	500	9,708	502	9,530	513	9,262	522	8,906	548	8,550
	77.7	16,493	71.6	16,191	71.4	15,737	71.2	15,132	69.0	14,527

Condiciones Estándar : 0 m.s.n.m. y 20°C.



Dimensiones **DALH 16**

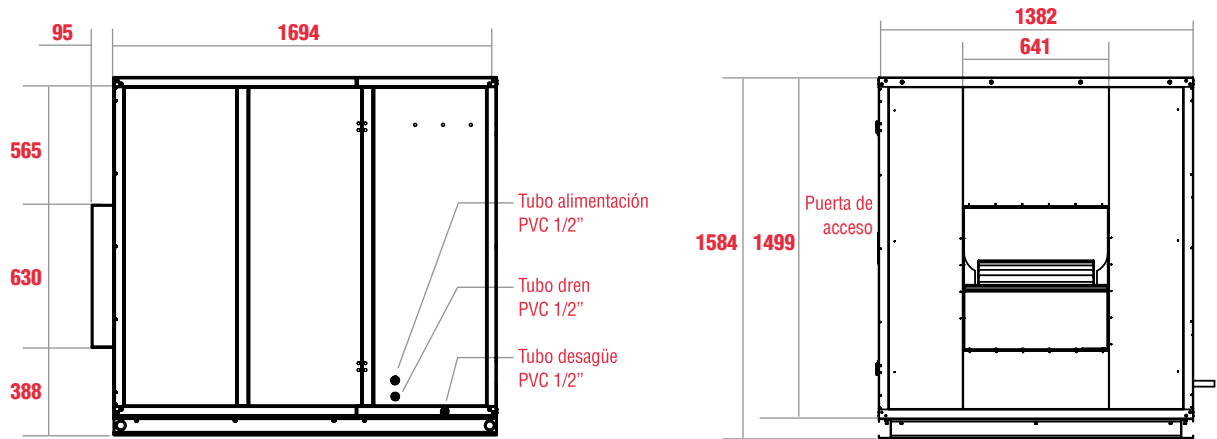

Dimensiones **DALV 16**

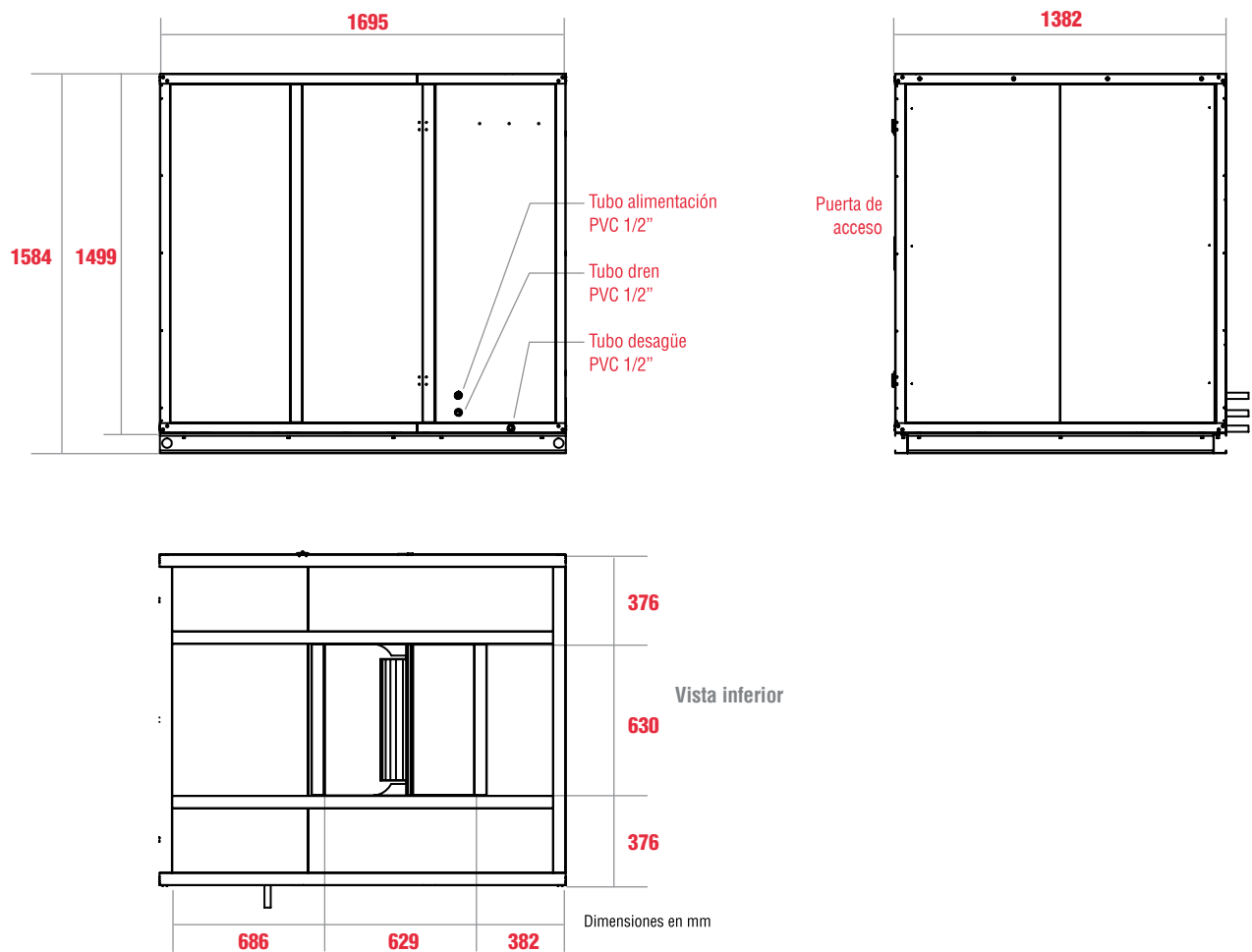



Características principales **DAL 25**

	Especificación				
	No. Paredes	Área de paso	Panel de enfriamiento evaporativo		Espesor
Área filtrante	1	25 ft <sup>2</sup> [ 2.32 m <sup>2</sup> ]	Papel corrugado 100% celulosa de madera, así como resinas de la más alta calidad. Contiene aditivos y bactericidas especiales para evitar la formación de microorganismos y espuma.		12 in [304.8 mm]
Bomba	Modelo	Voltaje	Hz	Potencia HP	Nota
	CP2-115 Little Giant	115	60	1/50	Estándar
Componentes	Chumaceras	Número de tinas		Capacidad en Litros por tina	
	De piso	1		60	
Conjunto	Caudal Máx.	Presión Est. Máx.	Potencia Máx.	Velocidad de paso Máx.	RPM Máx.
	16098 CFM [ 27350 m <sup>3</sup> /hr ]	1.5 inwg [ 38.1 mmca ]	3.73 Kw [ 5 HP ]	610 ft/min [ 3.1 m/seg ]	584
Accesorios	Louver en succión	Damper en succión	Malla desplegada en succión	Portafiltras / Filtras metálico	Tina de acero inoxidable

HP	PRESIÓN ESTÁTICA inwg / mmca											
	0.250" / 6.35 mm		0.312" / 7.93 mm		0.375" / 9.53 mm		0.438" / 11.11 mm		0.500" / 12.7 mm		0.625" / 15.87 mm	
	RPM dB(A)	CFM m <sup>3</sup> /hr	RPM dB(A)	CFM m <sup>3</sup> /hr	RPM dB(A)	CFM m <sup>3</sup> /hr	RPM dB(A)	CFM m <sup>3</sup> /hr	RPM dB(A)	CFM m <sup>3</sup> /hr	RPM dB(A)	CFM m <sup>3</sup> /hr
1	298	8550	300	8015	308	7392	317	6769	342	6338	363	5429
	62.7	14527	62.9	13618	60.7	12559	61.5	11500	61.2	10769	60.5	9224
1 1/2	315	9980	322	9633	329	9199	344	8851	358	8504	385	7723
	65.2	16956	65.6	16366	64.0	15629	65.2	15039	64.7	14449	64.7	13122
2	350	11362	359	10878	365	10636	370	10066	375	9719	396	9025
	67.7	19304	68.1	18482	66.7	18071	67.3	17103	66.6	16513	66.6	15333
3	406	13054	404	12691	403	12329	402	12087	400	11604	425	10999
	70.9	22179	71.0	21563	69.3	20947	70.1	20536	69.0	19714	69.5	18688
5	475	15273	478	14926	480	14752	485	14578	491	14405	496	14058
	74.3	25949	74.6	25359	73.1	25064	74.2	24769	73.7	24474	73.7	23884

HP	PRESIÓN ESTÁTICA inwg / mmca											
	0.687" / 17.46 mm		0.750" / 19.05 mm		0.874" / 22.22 mm		1.000" / 25.4 mm		1.250" / 31.75 mm		1.500" / 38.1 mm	
	RPM dB(A)	CFM m <sup>3</sup> /hr	RPM dB(A)	CFM m <sup>3</sup> /hr	RPM dB(A)	CFM m <sup>3</sup> /hr	RPM dB(A)	CFM m <sup>3</sup> /hr	RPM dB(A)	CFM m <sup>3</sup> /hr	RPM dB(A)	CFM m <sup>3</sup> /hr
1	387	5125	406	4738	449	4128						
	60.7	8707	59.8	8050	59.8	7013						
1 1/2	392	7116	401	6646	437	6030	483	5432				
	64.2	12090	63.1	11292	63.3	10245	61.3	9229				
2	403	8678	410	8331	438	7550	469	6942	536	5784		
	66.5	14744	65.6	14154	65.6	12827	63.4	11794	66.6	9827		
3	433	10697	440	10184	456	9633	477	9199	521	7984	576	7376
	69.4	18175	66.4	17303	68.6	16366	66.5	15629	69.6	13564	69.9	12532
5	498	13885	499	13537	500	13054	511	12691	547	11724	584	11120
	73.7	23590	72.8	23000	72.7	22179	70.5	21563	74.0	19919	74.2	18893

Condiciones Estándar : 0 m.s.n.m. y 20°C.



Dimensiones **DALH 25**

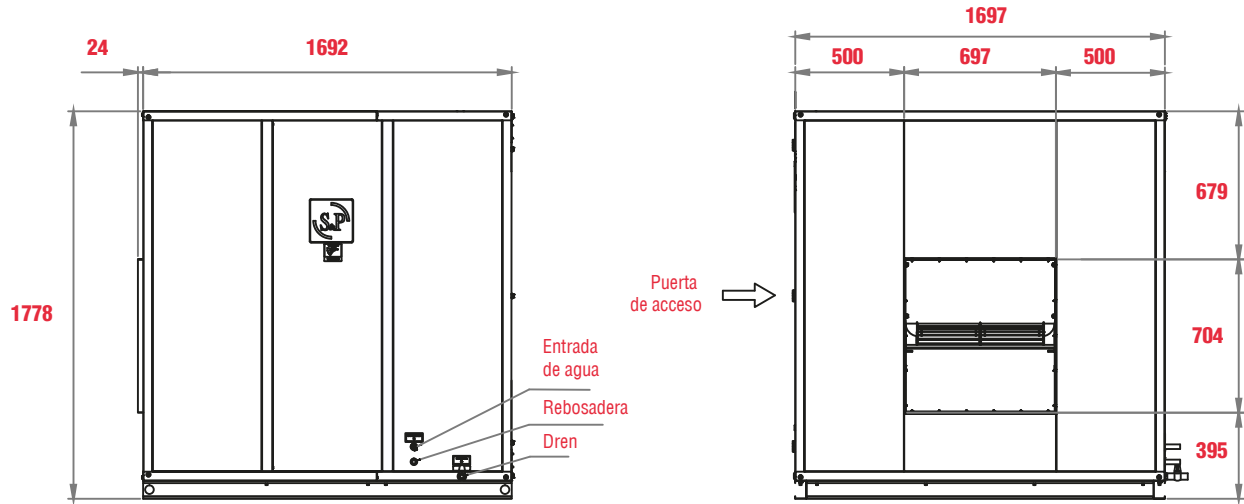

Dimensiones **DALV 25**

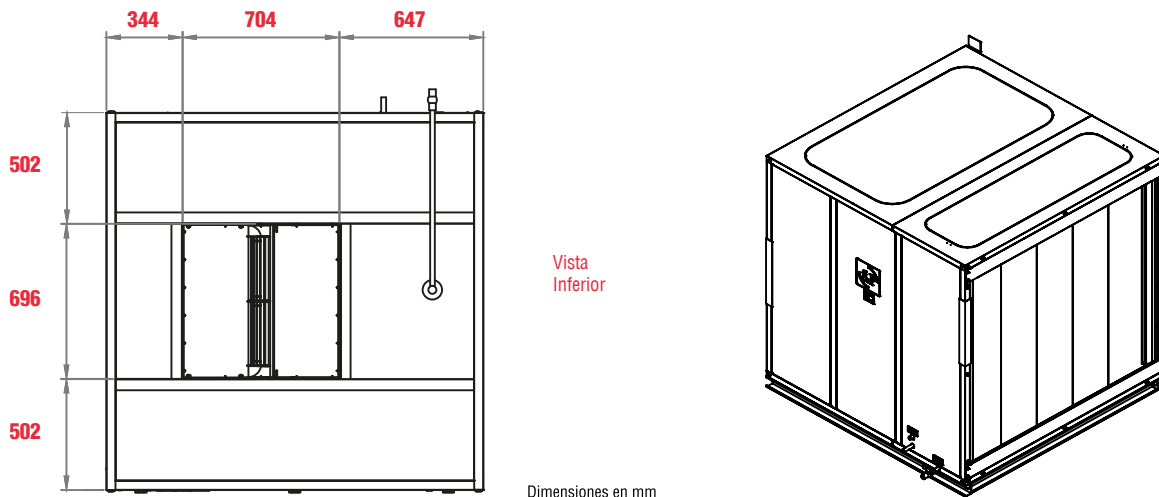
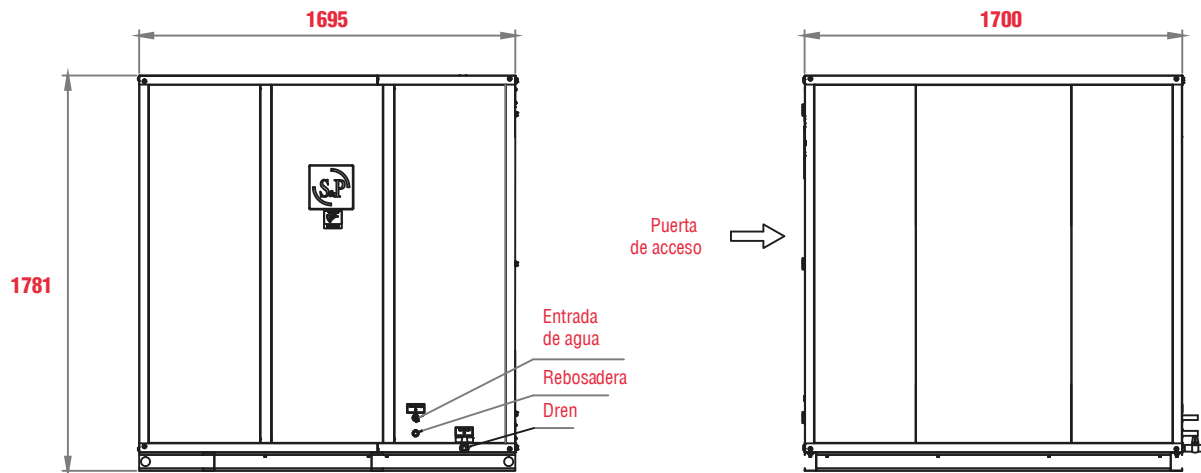

Dimensiones en mm



Características principales **DAL 36**

	Especificación				
	No. Paredes	Área de paso	Panel de enfriamiento evaporativo		Espesor
Área filtrante	1	36 ft² [ 3.34 m² ]	Papel corrugado 100% celulosa de madera, así como resinas de la más alta calidad. Contiene aditivos y bactericidas especiales para evitar la formación de microorganismos y espuma.		12 in [304.8 mm]
Bomba	Modelo	Voltaje	Hz	Potencia HP	Nota
	5 MSP - Little Giant	127	60	1/6	Estándar
Componentes	Chumaceras	Número de tinas		Capacidad en Litros por tina	
	De piso	1		85	
Conjunto	Caudal Máx.	Presión Est. Máx.	Potencia Máx.	Velocidad de paso Máx.	RPM Máx.
	24,279 CFM [ 41,250 m³/hr ]	1.5 inwg [ 38.1 mmca ]	7.46 Kw [ 10 HP ]	698 ft/min [ 3.54 m/seg ]	552
Accesorios	Louver en succión	Damper en succión	Malla desplegada en succión	Portafiltras / Filtras metálico	Tina de acero inoxidable

HP	PRESIÓN ESTÁTICA inwg / mmca											
	0.250" / 6.35 mm		0.312" / 7.93 mm		0.375" / 9.52 mm		0.438" / 11.11 mm		0.500" / 12.7 mm		0.625" / 15.87 mm	
	RPM dB(A)	CFM m³/hr	RPM dB(A)	CFM m³/hr	RPM dB(A)	CFM m³/hr	RPM dB(A)	CFM m³/hr	RPM dB(A)	CFM m³/hr	RPM dB(A)	CFM m³/hr
1 1/2	252	10375	272	10035	281	9712	297	9403	310	9249	333	8324
	62.2	17628	64.0	17050	63.6	16500	63.5	15976	63.8	15714	63.8	14143
2	264	11870	278	11438	298	11114	311	10790	321	10575	347	9820
	64.1	20167	65.6	19433	65.6	18883	65.4	18332	65.5	17967	65.9	16683
3	312	14028	319	13720	328	13565	336	13180	344	12949	361	12382
	67.7	23833	69.0	23310	68.8	23048	68.3	22393	68.4	22000	68.7	21038
5	353	17573	361	17111	369	16957	377	16957	382	16648	400	15724
	71.4	29857	72.7	29071	72.4	28810	72.2	28810	72.2	28286	72.3	26714
7 1/2	380	19446	390	19435	400	19423	409	19204	438	19269	441	18807
	73.3	33040	74.9	33021	74.7	33000	74.4	32628	75.2	32738	75.3	31952
10	426	23739	429	23524	443	23092	450	22876	453	22670	474	22229
	76.6	40333	77.8	39967	77.6	39233	77.3	38867	77.2	38517	77.8	37767

HP	PRESIÓN ESTÁTICA inwg / mmca											
	0.687" / 17.46 mm		0.750" / 19.05 mm		0.874" / 22.22 mm		1.000" / 25.4 mm		1.250" / 31.75 mm		1.500" / 38.1 mm	
	RPM dB(A)	CFM m³/hr	RPM dB(A)	CFM m³/hr	RPM dB(A)	CFM m³/hr	RPM dB(A)	CFM m³/hr	RPM dB(A)	CFM m³/hr	RPM dB(A)	CFM m³/hr
1 1/2	347	7708	352	7245	395	6366						
	63.5	13095	62.4	12310	62.7	10817						
2	357	9403	365	9095	392	8478	422	7553				
	65.8	15976	65.1	15452	65.5	14405	63.0	12833				
3	376	12086	383	11762	400	11114	421	10373	463	8941	518	7708
	68.9	20534	68.3	19983	68.4	18883	66.3	17623	69.3	15190	69.0	13095
5	409	15416	412	15107	432	14799	448	14182	477	12733	520	11546
	72.4	26191	71.7	25667	72.3	25143	70.1	24095	73.2	21633	73.2	19617
7 1/2	449	18652	454	18099	461	18190	483	17882	510	16648	541	15569
	75.4	31690	74.6	30750	75.1	30905	73.3	30381	76.7	28286	76.7	26452
10	480	21797	491	21581	502	21150	511	20718	547	19269	552	18344
	77.7	37033	77.3	36667	77.6	35933	74.0	35200	79.0	32738	78.5	31167

Condiciones Estándar : 0 m.s.n.m. y 20°C.



Dimensiones **DALH 36**

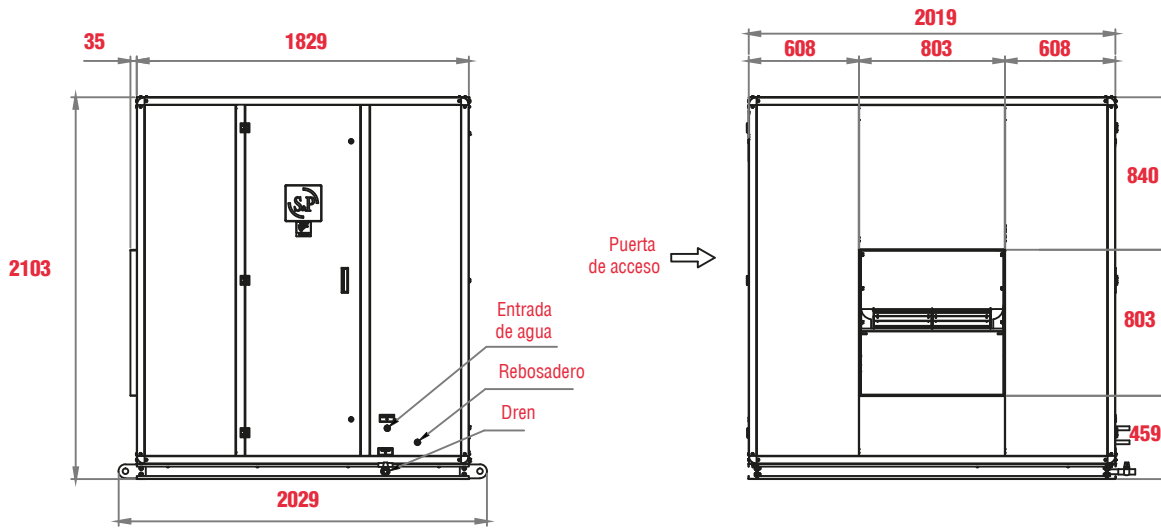

Dimensiones **DALV 36**

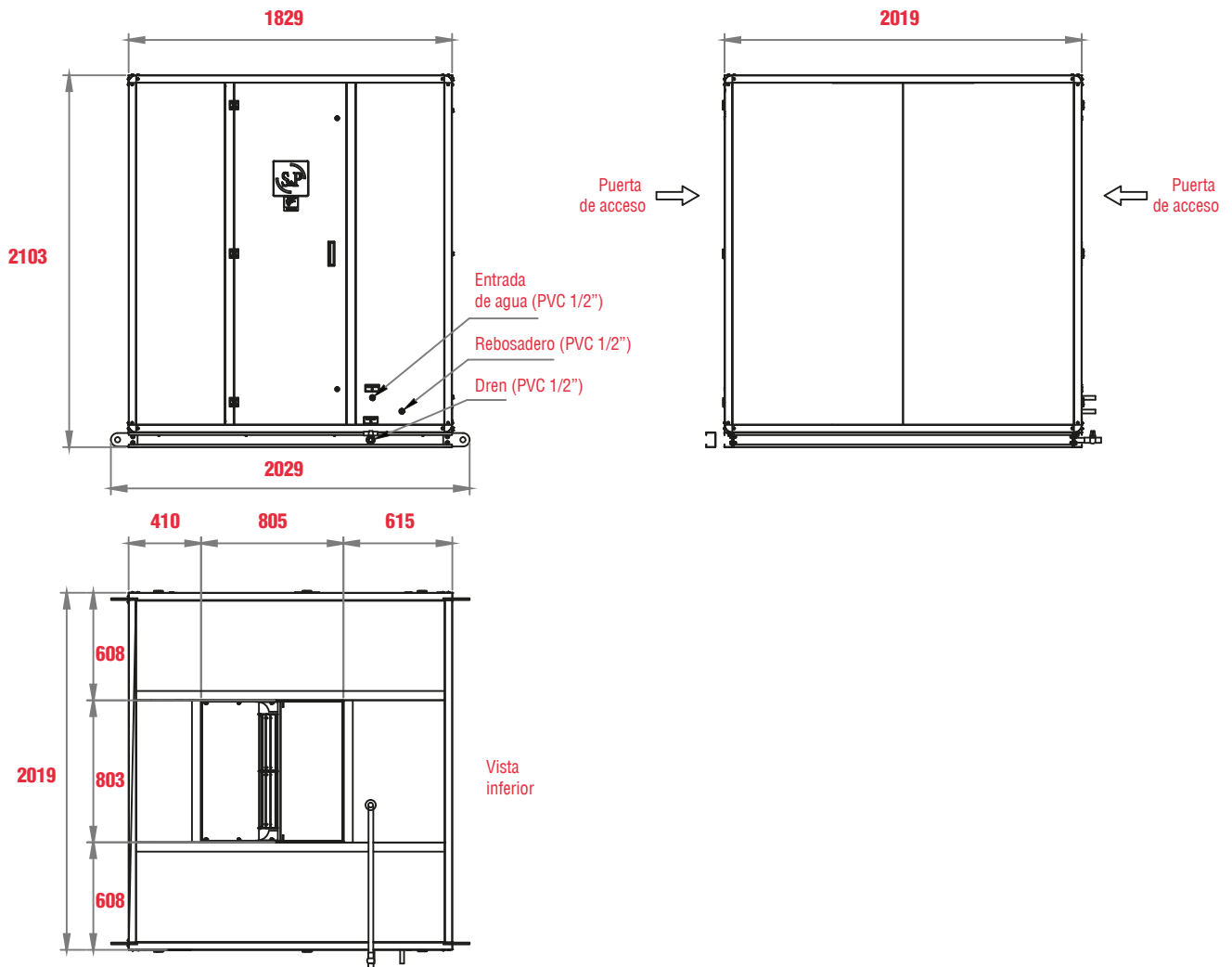



Características principales **DAL 45**

	Especificación				
	No. Paredes	Área de paso	Panel de enfriamiento evaporativo		Espesor
Área filtrante	1	45 ft <sup>2</sup> [ 4.18 m <sup>2</sup> ]	Papel corrugado 100% celulosa de madera, así como resinas de la más alta calidad. Contiene aditivos y bactericidas especiales para evitar la formación de microorganismos y espuma.		12 in [304.8 mm]
	Modelo	Voltaje	Hz	Potencia HP	Nota
Bomba	5 MSP- Little Giant	127	60	1/16	Estándar
Componentes	Chumaceras	Número de tinas		Capacidad en Litros por tina	
	De piso	1		109	
Conjunto	Caudal Máx.	Presión Est. Máx.	Potencia Máx.	Velocidad de paso Máx.	RPM Máx.
	26251 CFM [ 44600 m <sup>3</sup> /hr ]	1.5 inwg [ 38.1 mmca ]	5.59 Kw [ 10 HP ]	583 ft/min [ 2.96 m/seg ]	407
Accesorios	Louwer en succión	Damper en succión	Malla desplegada en succión	Portafiltras / Filtras metálico	Tina de acero inoxidable

HP	PRESIÓN ESTÁTICA inwg / mmca											
	0.250" / 6.35 mm		0.312" / 7.93mm		0.375" / 9.52mm		0.438" / 11.11mm		0.500" / 12.7mm		0.625" / 15.87mm	
	RPM dB(A)	CFM m <sup>3</sup> /hr	RPM dB(A)	CFM m <sup>3</sup> /hr	RPM dB(A)	CFM m <sup>3</sup> /hr	RPM dB(A)	CFM m <sup>3</sup> /hr	RPM dB(A)	CFM m <sup>3</sup> /hr	RPM dB(A)	CFM m <sup>3</sup> /hr
1	158	8173	182	8173	202	8088	215	7833	226	7492	261	6353
	57.7	13886	59.7	13886	58.1	13742	56.6	13308	56.7	12729	54	10794
1 1/2	172	11448	192	11199	208	10701	221	10328	228	10017	254	9195
	62	19450	63.5	19027	61.3	18181	59.7	17547	59.3	17019	57.5	15622
2	198	14133	205	13367	217	12692	229	12443	232	12017	258	11075
	65.8	24012	66.1	22711	63.5	21564	62	21141	61.8	20417	59.5	18816
3	250	20105	242	18050	247	17368	248	17028	251	16687	263	15155
	72.1	34158	71	30667	68.2	29508	66.1	28931	66	28351	62.9	25748
5	272	22185	273	22185	275	21723	278	21261	285	21029	295	19400
	74	37692	74.5	37692	71.7	36907	69.7	36122	69.8	35728	61.4	32961
7 1/2	334	26223	320	25882	316	25651	314	25498	322	25420	318	24034
	79	44553	77.9	43974	74.9	43581	72.9	43321	73.2	43189	69.8	40834

HP	PRESIÓN ESTÁTICA inwg / mmca											
	0.687" / 17.46mm		0.750" / 19.05 mm		0.874" / 22.22mm		1.000" / 25.4 mm		1.250" / 31.75mm		1.500" / 38.1mm	
	RPM dB(A)	CFM m <sup>3</sup> /hr	RPM dB(A)	CFM m <sup>3</sup> /hr	RPM dB(A)	CFM m <sup>3</sup> /hr	RPM dB(A)	CFM m <sup>3</sup> /hr	RPM dB(A)	CFM m <sup>3</sup> /hr	RPM dB(A)	CFM m <sup>3</sup> /hr
1	277	5765	283	5130								
	52.8	9795	51.5	8716								
1 1/2	274	8769	290	8173	305	7322	333	6118				
	56.9	14899	56.5	13886	54.7	12440	52.7	10394				
2	276	10399	287	9955	305	9195	335	8259	374	6556		
	58.7	17668	58.4	16914	57	15632	55.8	14032	52.9	11139		
3	280	14474	285	13963	301	12817	328	11946	370	9937	407	8003
	62.2	24591	61.7	23723	60.2	21776	59.3	20296	56.9	16883	54.4	13597
5	299	19071	303	18731	322	17709	326	17028	368	14985	401	12510
	65.8	32402	65.4	31824	64.2	30088	62.8	28931	61	25460	58.7	21254
7 1/2	327	23387	328	23109	340	22416	348	21492	378	19071	403	17709
	69.1	39735	68.4	39262	67.3	38085	65.9	36515	63.8	32402	63.1	30088



Dimensiones **DALH 45**

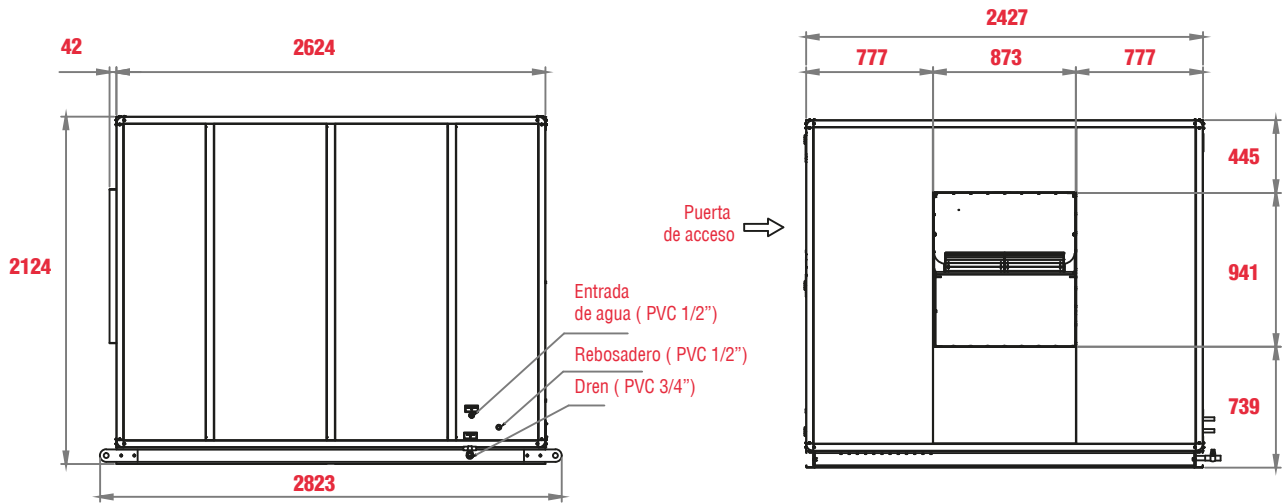

Dimensiones **DALV 45**

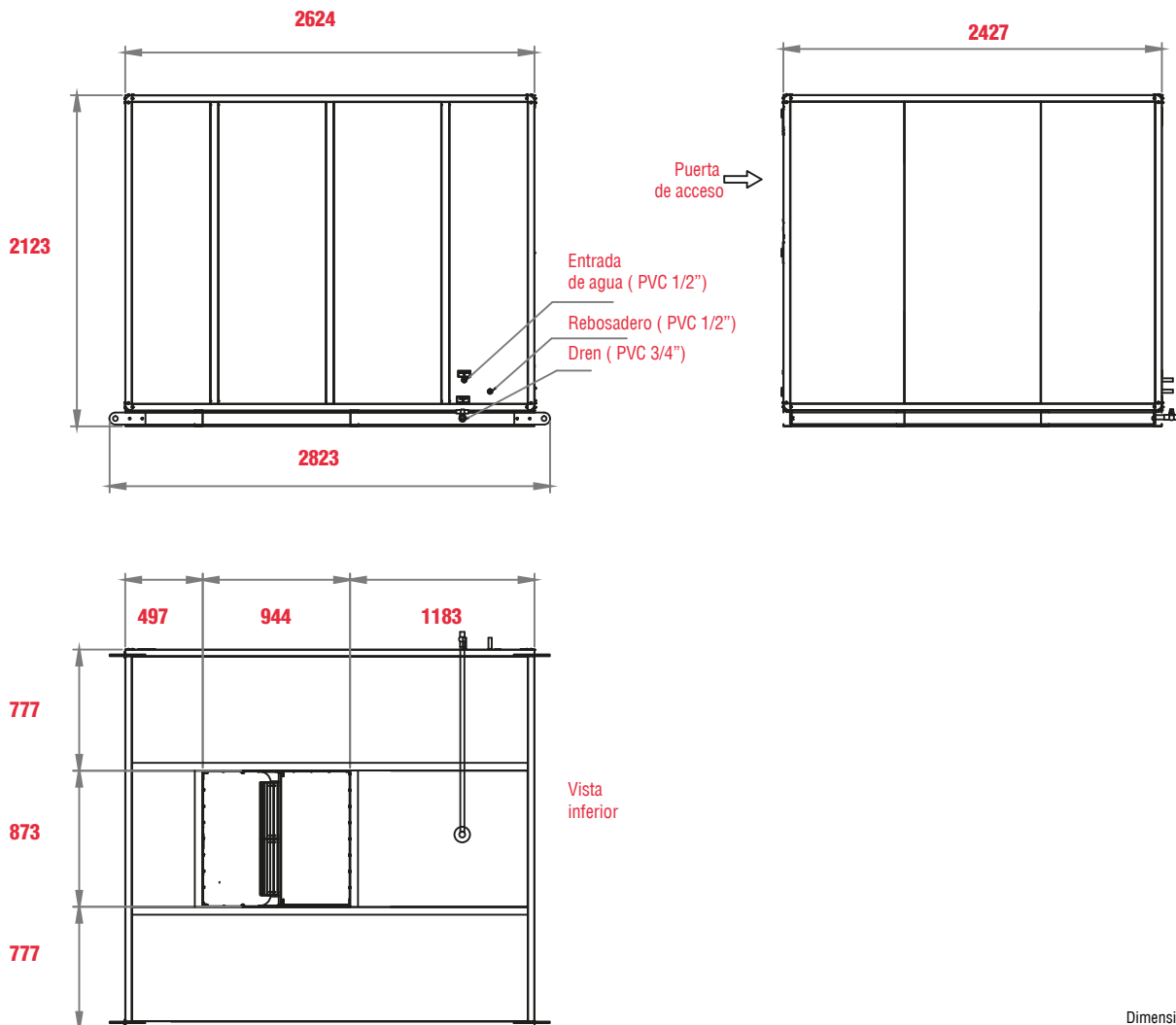



Características principales **DAL 72**

	Especificación				
	No. Paredes	Área de paso	Panel de enfriamiento evaporativo		Espesor
Área filtrante	2	72 ft <sup>2</sup> [ 6.69 m <sup>2</sup> ]	Papel corrugado 100% celulosa de madera, así como resinas de la más alta calidad. Contiene aditivos y bactericidas especiales para evitar la formación de microorganismos y espuma.		12 in [304.8 mm]
Bomba	Modelo	Voltaje	Hz	Potencia HP	Nota
	5 MSP - Little Giant	127	60	1/6	Estándar
Componentes	Chumaceras	Número de tinas		Capacidad en Litros por tina	
	De piso	2		87.58	
Conjunto	Caudal Máx.	Presión Est. Máx.	Potencia Máx.	Velocidad de paso Máx.	RPM Máx.
	38,258 CFM [65,000 m <sup>3</sup> /hr ]	1.5 inwg [ 38.1 mmca ]	14.91 Kw [ 20 HP ]	525 ft/min [ 2..66 m/seg ]	483
Accesorios	Louwer en succión	Damper en succión	Malla desplegada en succión	Portafiltras / Filtras metálico	Tina de acero inoxidable

HP	PRESIÓN ESTÁTICA inwg / mmca									
	0.25" / 6.35 mm		0.375" / 9.525 mm		0.500" / 12.7 mm		0.625" / 15.875 mm		0.75" / 19.05 mm	
	RPM dB(A)	CFM m <sup>3</sup> /hr	RPM dB(A)	CFM m <sup>3</sup> /hr	RPM dB(A)	CFM m <sup>3</sup> /hr	RPM dB(A)	CFM m <sup>3</sup> /hr	RPM dB(A)	CFM m <sup>3</sup> /hr
5	260	21,273	263	20,811	276	20,025	283	18,826	300	17,929
	70.4	36,143	70	35,357	73	34,022	73	31,985	73	30,461
7 1/2	305	25,204	308	24,972	312	24,857	320	24,074	332	23,185
	74.0	42,822	76	42,428	77	42,232	77	40,901	77	39,391
10	341	28,487	342	28,210	343	28,078	344	27,532	350	26,393
	77	48,400	79	47,928	79	47,704	79	46,778	79	44,842
15	415	33,613	420	33,495	424	33,345	427	33,363	412	32,834
	80	57,109	83	56,909	83	56,653	83	56,684	83	55,785
20	455	37,789	449	37,459	450	37,195	455	37,195	455	36,931
	84	64,204	85	63,643	85	63,194	85	63,194	85	62,745

HP	PRESIÓN ESTÁTICA inwg / mmca									
	0.875" / 22.225 mm		1.000" / 25.4 mm		1.125" / 28.575 mm		1.250" / 31.750 mm		1.500" / 38.1 mm	
	RPM dB(A)	CFM m <sup>3</sup> /hr	RPM dB(A)	CFM m <sup>3</sup> /hr	RPM dB(A)	CFM m <sup>3</sup> /hr	RPM dB(A)	CFM m <sup>3</sup> /hr	RPM dB(A)	CFM m <sup>3</sup> /hr
5	316	16,933	327	15,937	350	14,729	372	13,613	385	12,854
	73	28,769	73	27,077	73	25,025	75	23,129	77	21,838
7 1/2	340	22,159	348	21,247	360	20,117	380	18,925	390	18,261
	77	37,648	77	36,099	77	34,178	79	32,154	81	31,026
10	357	25,852	364	25,123	378	24,279	390	23,527	400	22,843
	79	43,922	79	42,683	79	41,250	81	39,972	83	38,810
15	410	32,108	411	31,051	408	29,912	419	29,201	425	28,210
	83	54,551	83	52,755	82	50,820	84	49,612	86	47,928
20	460	36,534	468	35,873	470	35,285	480	33,825	485	31,825
	85	62,072	85	60,949	84	59,950	86	57,468	89	54,071

Condiciones Estándar : 0 m.s.n.m. y 20°C.



Dimensiones **DALH 72**

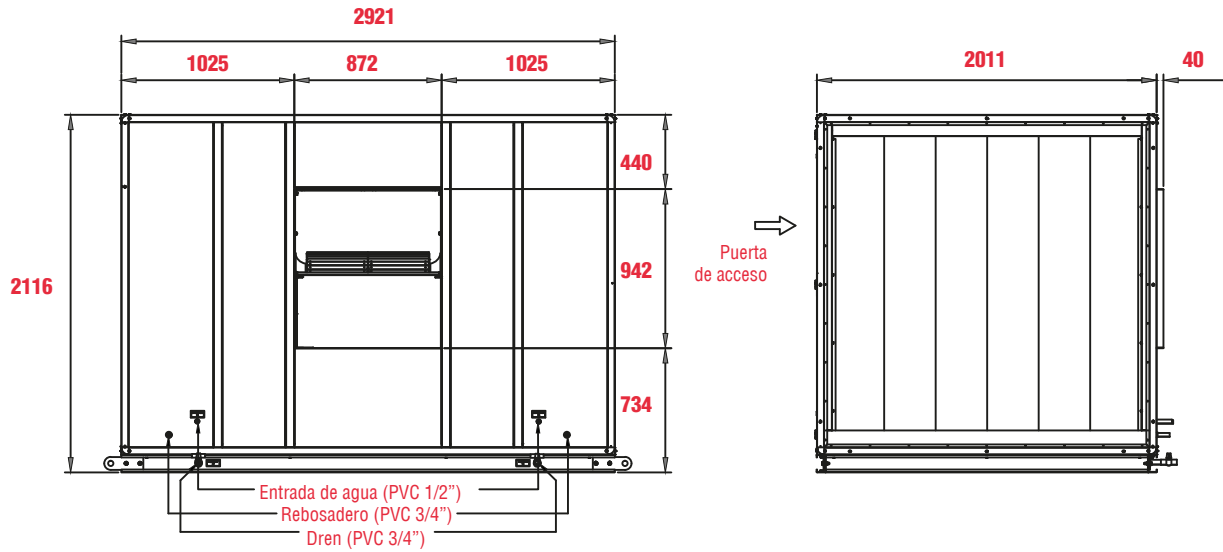

Dimensiones **DALV 72**

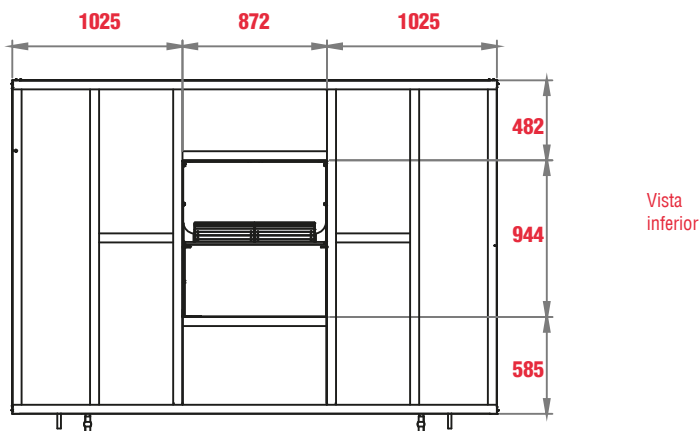
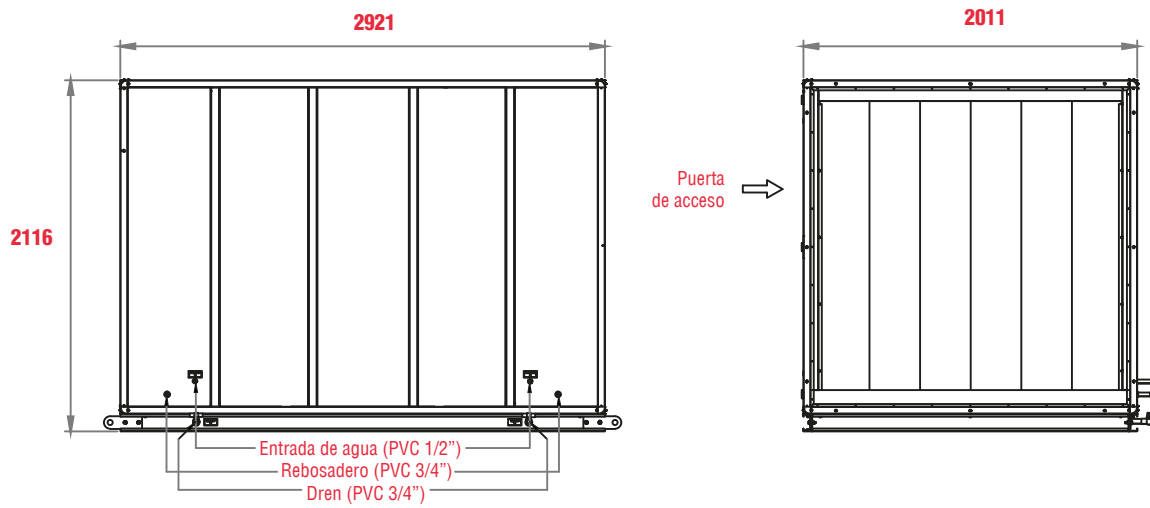



Características principales **DAL 96**

	Especificación				
	No. Paredes	Área de paso	Panel de enfriamiento evaporativo		Espesor
Área filtrante	2	96 ft <sup>2</sup> [ 8.92 m <sup>2</sup> ]	Papel corrugado 100% celulosa de madera, así como resinas de la más alta calidad. Contiene aditivos y bactericidas especiales para evitar la formación de microorganismos y espuma.		12 in [304.8 mm]
	Modelo	Voltaje	Hz	Potencia HP	Nota
Bomba	5 MSP - Little Giant	127	60	1/6	Estándar
Componentes	Chumaceras	Número de tinas		Capacidad en Litros por tina	
	De piso	2		211.95	
Conjunto	Caudal Máx.	Presión Est. Máx.	Potencia Máx.	Velocidad de paso Máx.	RPM Máx.
	60,330 CFM [ 102,500 m <sup>3</sup> /hr ]	1.5 inwg [ 38.1 mmca ]	29.84 Kw [ 40 HP ]	628 ft/min [ 3.19 m/seg ]	402
Accesorios	Louwer en succión	Damper en succión	Malla desplegada en succión	Portafiltras / Filtras metálico	Tina de acero inoxidable

HP	PRESIÓN ESTÁTICA inwg / mmca									
	0.25" / 6.35 mm		0.375" / 9.525 mm		0.500" / 12.7 mm		0.625" / 15.875 mm		0.75" / 19.05 mm	
	RPM dB(A)	CFM m <sup>3</sup> /hr	RPM dB(A)	CFM m <sup>3</sup> /hr	RPM dB(A)	CFM m <sup>3</sup> /hr	RPM dB(A)	CFM m <sup>3</sup> /hr	RPM dB(A)	CFM m <sup>3</sup> /hr
10	238	36,442	242	35,944	250	35,572	258	34,630	265	33,667
	79.8	61,915	76.2	61,069	73.7	60,437	71.7	58,837	69.9	57,200
15	275	42,916	280	42,731	278	42,422	290	41,823	290	40,696
	84.5	72,915	80.9	72,600	78.4	72,075	76.4	71,058	74.7	69,143
20	300	47,356	305	47,128	303	46,525	310	46,288	315	45,506
	87.1	80,457	83.5	80,070	81.0	79,046	79.0	78,643	77.3	77,315
25	320	51,055	325	50,874	331	50,685	338	50,315	341	49,575
	89.1	86,743	85.6	86,435	83.1	86,115	81.1	85,485	79.4	84,228
30	352	55,495	354	55,559	352	55,183	364	54,806	360	54,385
	91.1	94,285	87.5	94,395	85.0	93,756	83.0	93,116	81.4	92,400

HP	PRESIÓN ESTÁTICA inwg / mmca									
	0.875" / 22.225 mm		1.000" / 25.4 mm		1.125" / 28.575 mm		1.250" / 31.750 mm		1.500" / 38.1 mm	
	RPM dB(A)	CFM m <sup>3</sup> /hr	RPM dB(A)	CFM m <sup>3</sup> /hr	RPM dB(A)	CFM m <sup>3</sup> /hr	RPM dB(A)	CFM m <sup>3</sup> /hr	RPM dB(A)	CFM m <sup>3</sup> /hr
10	278	32,187	290	31,077	300	29,597	313	28,118	343	24,048
	68.4	54,685	67.1	52,800	65.9	50,285	64.7	47,772	62.5	40,857
15	302	39,956	310	39,032	312	37,737	325	36,626	347	34,037
	73.3	67,885	72.0	66,315	70.8	64,115	69.8	62,228	67.9	57,828
20	320	44,766	325	44,042	333	43,286	340	42,361	355	40,696
	75.9	76,057	74.7	74,828	73.6	73,543	72.6	71,972	70.8	69,143
25	345	49,205	347	48,465	350	47,725	354	47,171	370	45,506
	78.1	83,600	76.9	82,343	75.8	81,085	74.8	80,143	73.1	77,315
30	360	54,015	363	53,275	366	52,535	370	51,795	379	46,246
	80.1	91,771	78.8	90,515	77.8	89,257	76.7	88,000	74.7	78,572

Condiciones Estándar : 0 m.s.n.m. y 20°C.



Dimensiones **DALH 96**

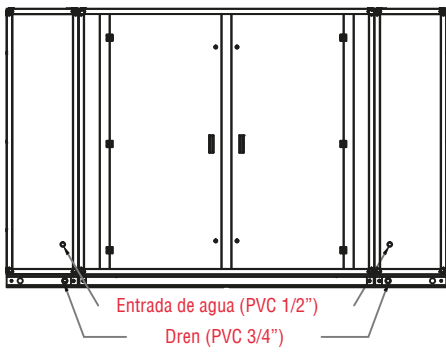
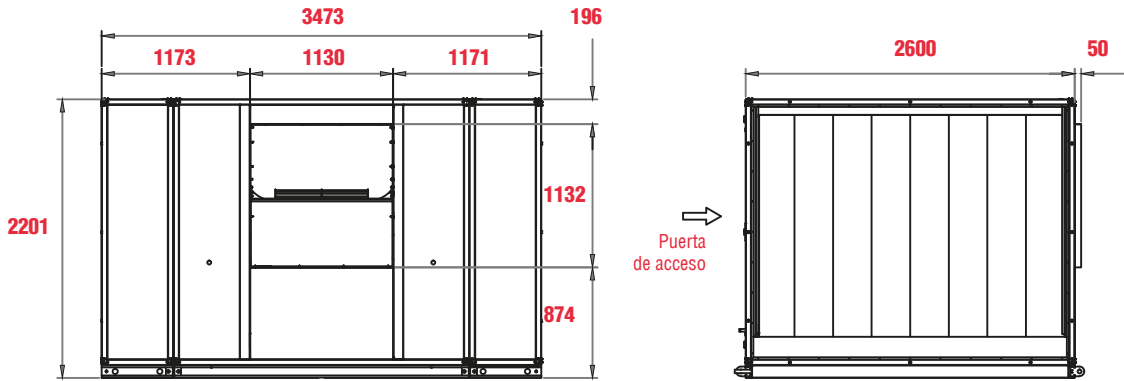

Dimensiones **DALV 96**

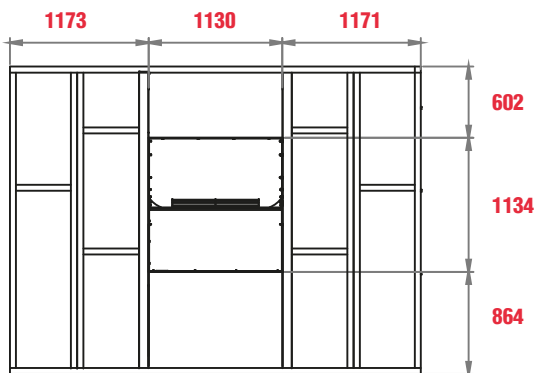
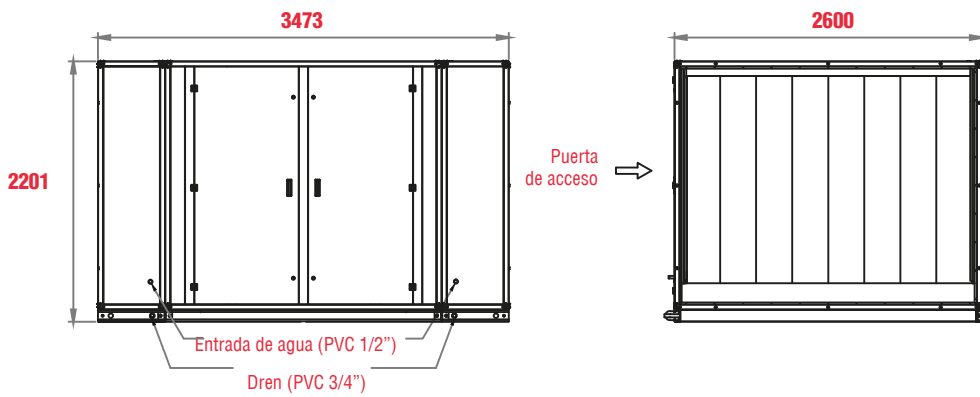

Dimensiones en mm

# Principales temperaturas de la República Mexicana

Estado	Ciudad	Temperatura Bulbo Seco °C	Temperatura Bulbo Húmedo °C
<b>Aguascalientes</b>			
	Aguascalientes	34	17
<b>Baja California</b>			
	Ensenada	34	26
	Mexicali	43	28
	La Paz	36	28
	Tijuana	25	26
<b>Campeche</b>			
	Campeche	36	26
	Ciudad del Carmen	37	26
<b>Coahuila</b>			
	Monclova	38	24
	Nueva Rosita	41	25
	Piedras Negras	40	26
	Saltillo	35	22
<b>Colima</b>			
	Colima	36	24
	Manzanillo	35	27
<b>Chiapas</b>			
	Tapachula	34	25
	Tuxtla Gutiérrez	35	25
<b>Chihuahua</b>			
	Chihuahua	35	23
	Ciudad Juárez	37	24
<b>Ciudad de México</b>			
	Ciudad de México	32	17
<b>Durango</b>			
	Durango	33	17
	Ciudad Lerdo	36	21
<b>Guanajuato</b>			
	Celaya	38	20
	Guanajuato	32	18
	León	34	20
	Salvatierra	35	19
<b>Guerrero</b>			
	Acapulco	33	27
	Chilpancingo	33	23
	Taxo	34	20
<b>Hidalgo</b>			
	Pachuca	29	18
	Tulancingo	32	19
<b>Jalisco</b>			
	Guadalajara	33	20
	Lagos	39	20
	Puerto Vallarta	36	26
<b>Estado de México</b>			
	Tepotzotlán	32	17
	Toluca	26	17
<b>Michoacán</b>			
	Apatzingán	39	25
	Morelia	30	19
	Zamora	35	20
	Zacapu	32	19

Estado	Ciudad	Temperatura Bulbo Seco °C	Temperatura Bulbo Húmedo °C
<b>Morelos</b>			
	Cuatlúa	42	22
	Cuernavaca	31	20
<b>Nayarit</b>			
	San Blas	33	26
	Tepic	36	26
<b>Nuevo León</b>			
	Montemorelos	39	25
	Monterrey	38	25
<b>Oaxaca</b>			
	Oaxaca	35	22
	Salina Cruz	34	26
<b>Puebla</b>			
	Puebla	29	17
	Tehuacán	34	20
<b>Querétaro</b>			
	Querétaro	33	21
<b>Quintana Roo</b>			
	Cozumel	33	27
<b>San Luis Potosí</b>			
	San Luis Potosí	34	18
<b>Sinaloa</b>			
	Culiacán	37	27
	Mazatlán	31	26
	Topolobampo	37	27
<b>Sonora</b>			
	Guaymas	42	22
	Hermosillo	41	28
	Nogales	37	26
	Ciudad Obregón	43	28
<b>Tabasco</b>			
	Villahermosa	37	26
<b>Tamaulipas</b>			
	Matamoros	36	26
	Nueva Laredo	41	25
	Tampico	36	28
	Ciudad Victoria	38	26
<b>Tlaxcala</b>			
	Tlaxcala	28	17
<b>Veracruz</b>			
	Xalapa	32	21
	Orizaba	34	21
	Veracruz	33	27
<b>Yucatán</b>			
	Mérida	37	27
	Progreso	36	27
<b>Zacatecas</b>			
	Fresnillo	36	19
	Zacatecas	28	17

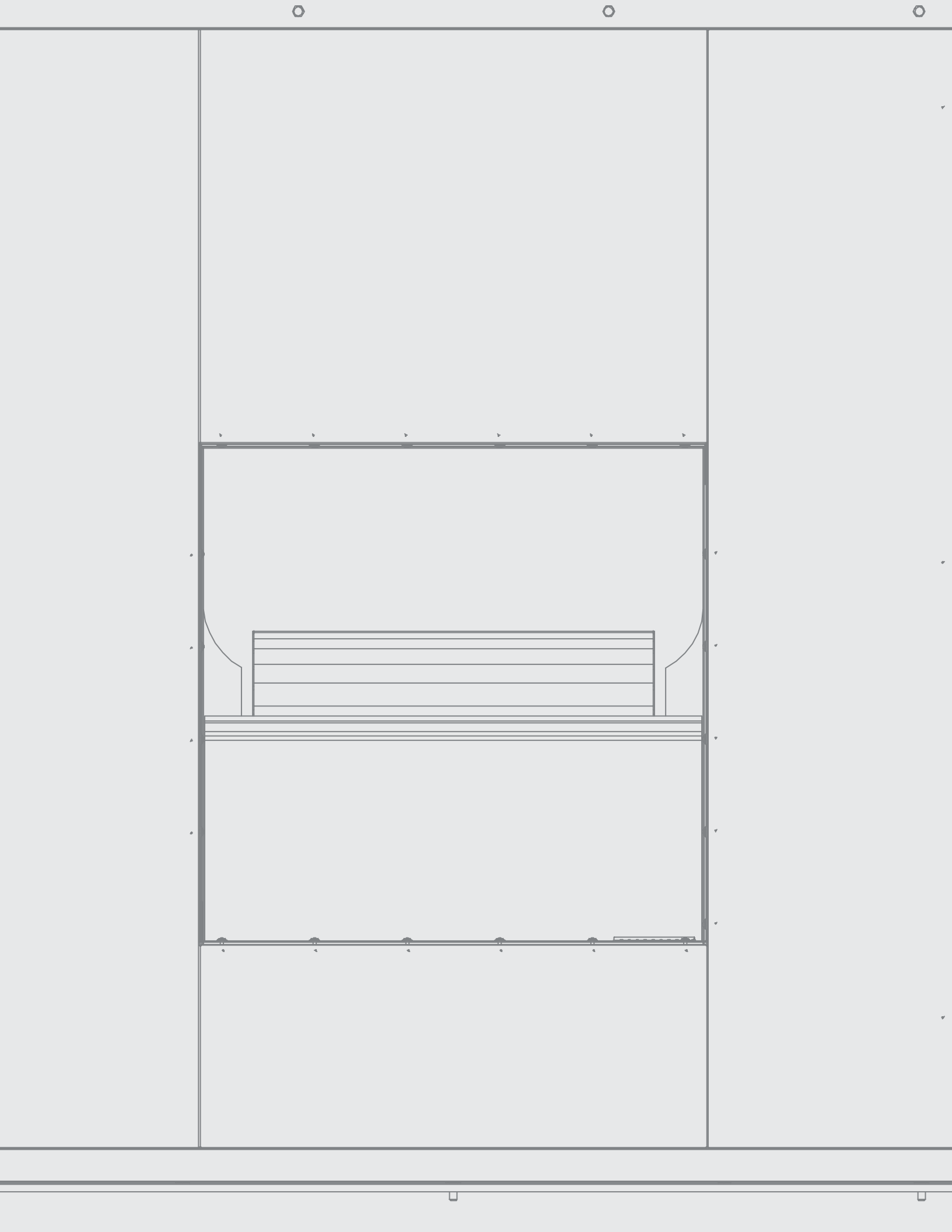



[www.solerpalau.mx](http://www.solerpalau.mx)

**S&P México**

Tel. 52 (222) 2 233 911, 2 233 900  
[comercialmx@solerpalau.com](mailto:comercialmx@solerpalau.com)

**S&P Colombia**

PBX: (+571 743 8021)  
[comercial@solerpalau.com.co](mailto:comercial@solerpalau.com.co)

**S&P Perú**

Tel. +51 (1) 200 9020  
[comercialpe@solerpalau.com](mailto:comercialpe@solerpalau.com)



**ISO 9001: 2015**

S&P México se reserva el derecho de  
modificación sin previo aviso.

DAL Marzo 2024